

LOC		DIST		REVISIONS			
P	LTR	DATE	BY	APV	DATE	BY	APV
AJ	16	C	PER EC	0514-0184-04	06JAN04	BM	JL

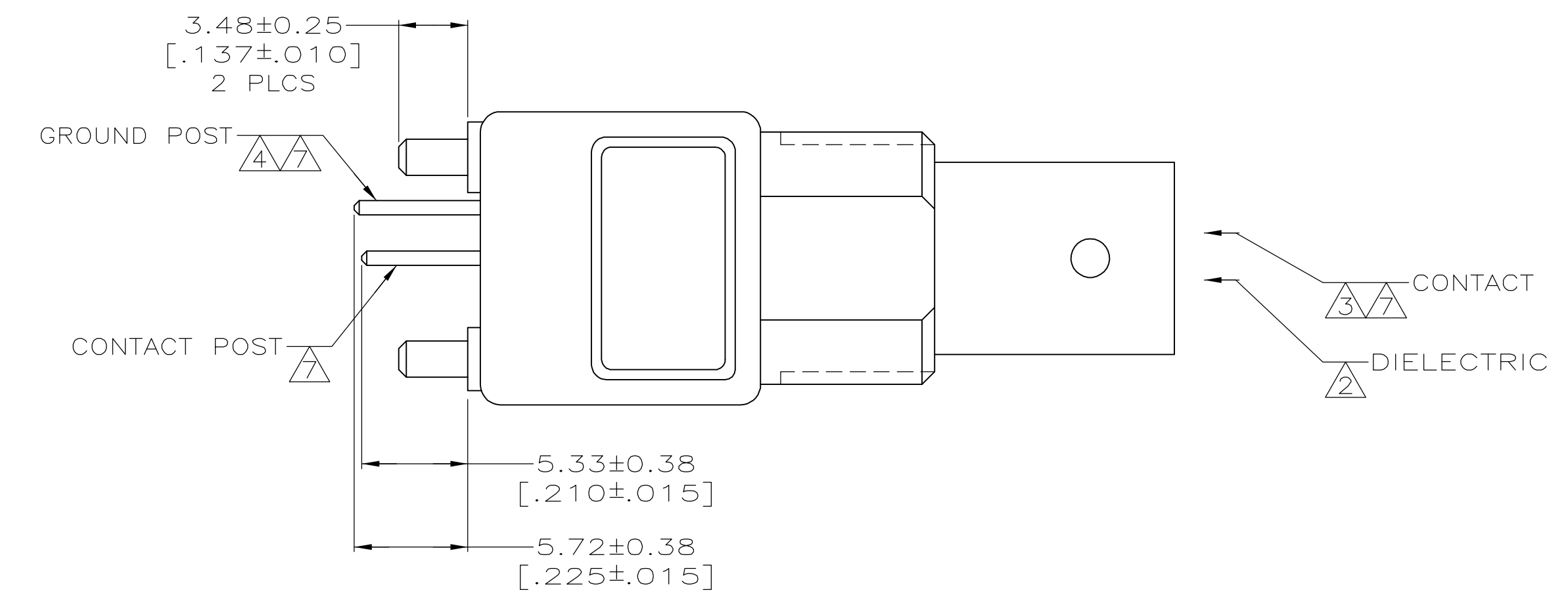

- ① ZINC PER QQ-Z-363.
- ② POLYMETHYLPENTENE PER ASTM-D-1238.
- ③ PHOSPHOR BRONZE PER QQ-B-750.
- ④ BRASS PER ASTM-B-453.
- ⑤ BRASS PER ASTM-B-16.
- ⑥ NICKEL PLATE PER QQ-N-290, 3.81 μm [.000150] MINIMUM THICK.
- ⑦ TIN PLATE PER ASTM-B-545, 3.81 μm [.000150] MINIMUM THICK.
- 8. SEE INSTRUCTION SHEET 2769.

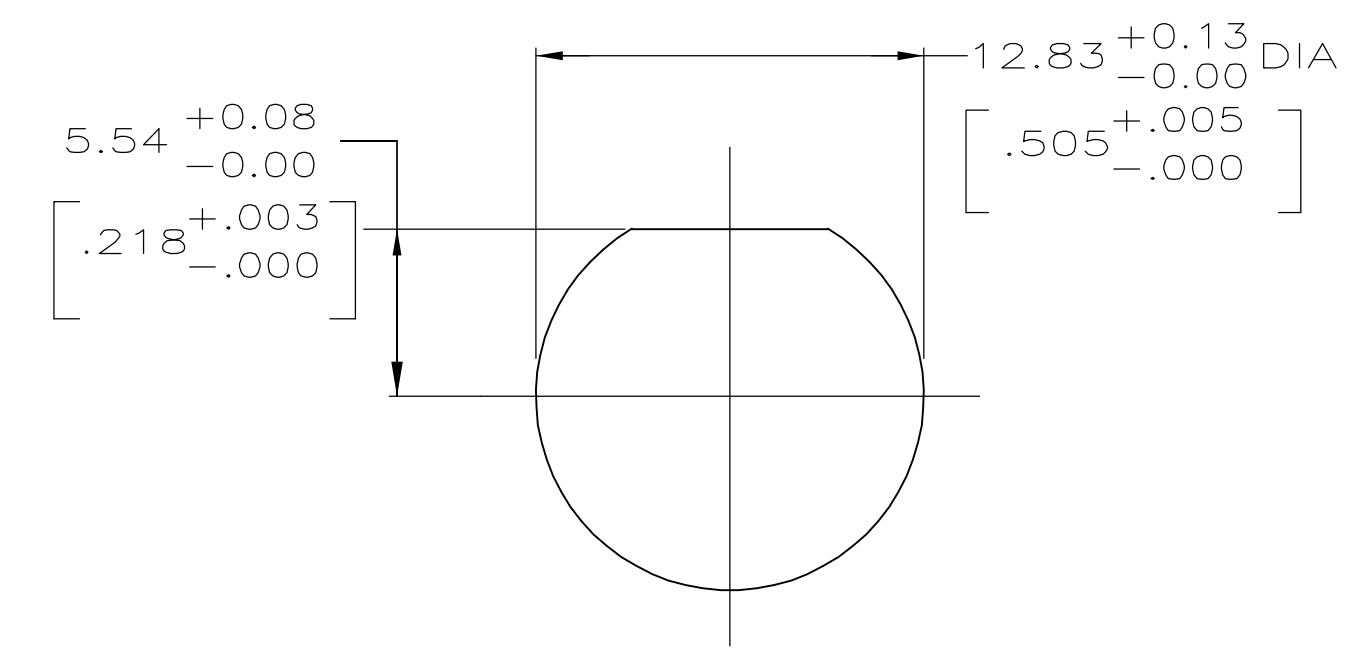
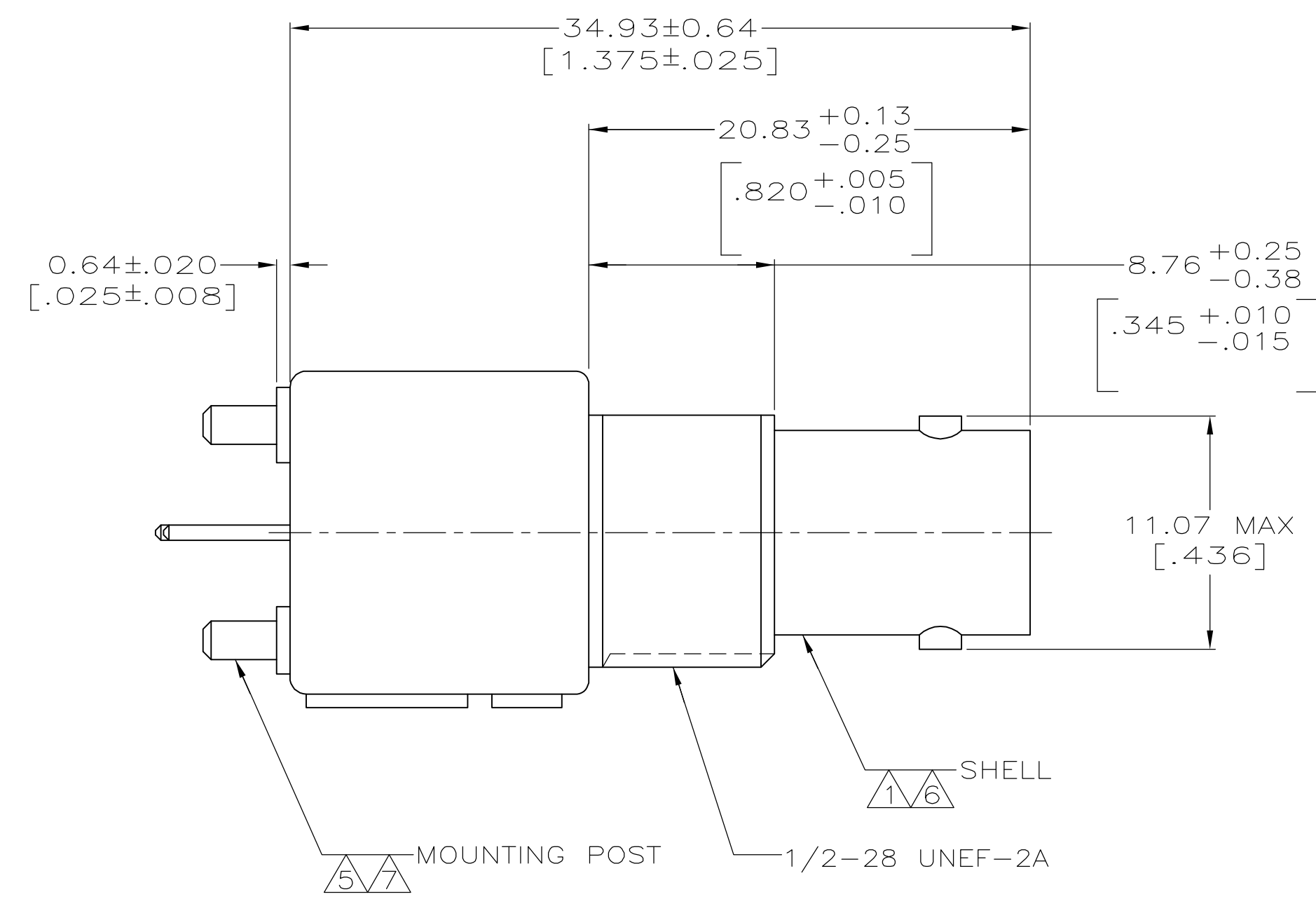
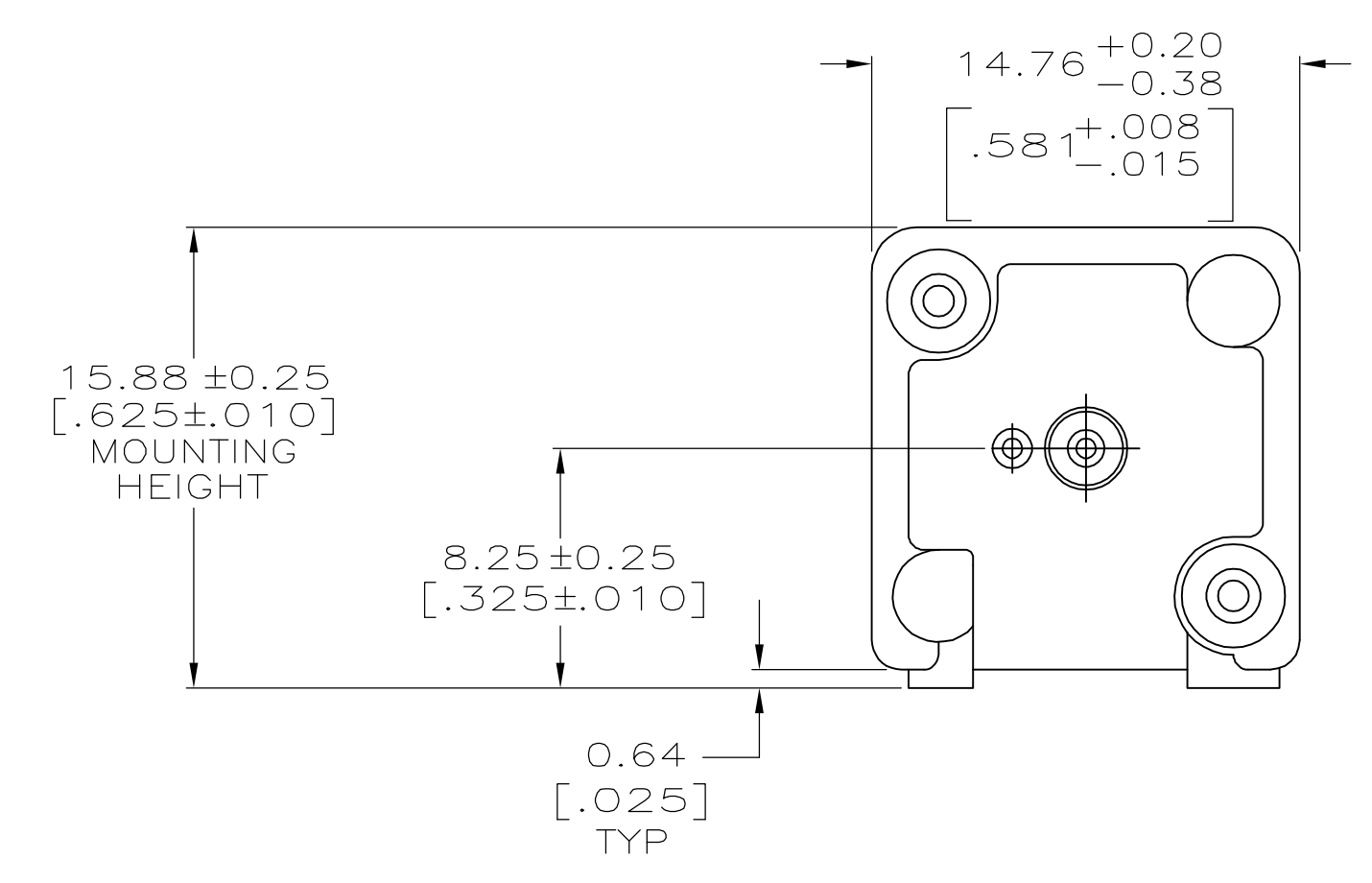

RECOMMENDED PANEL CUTOUT

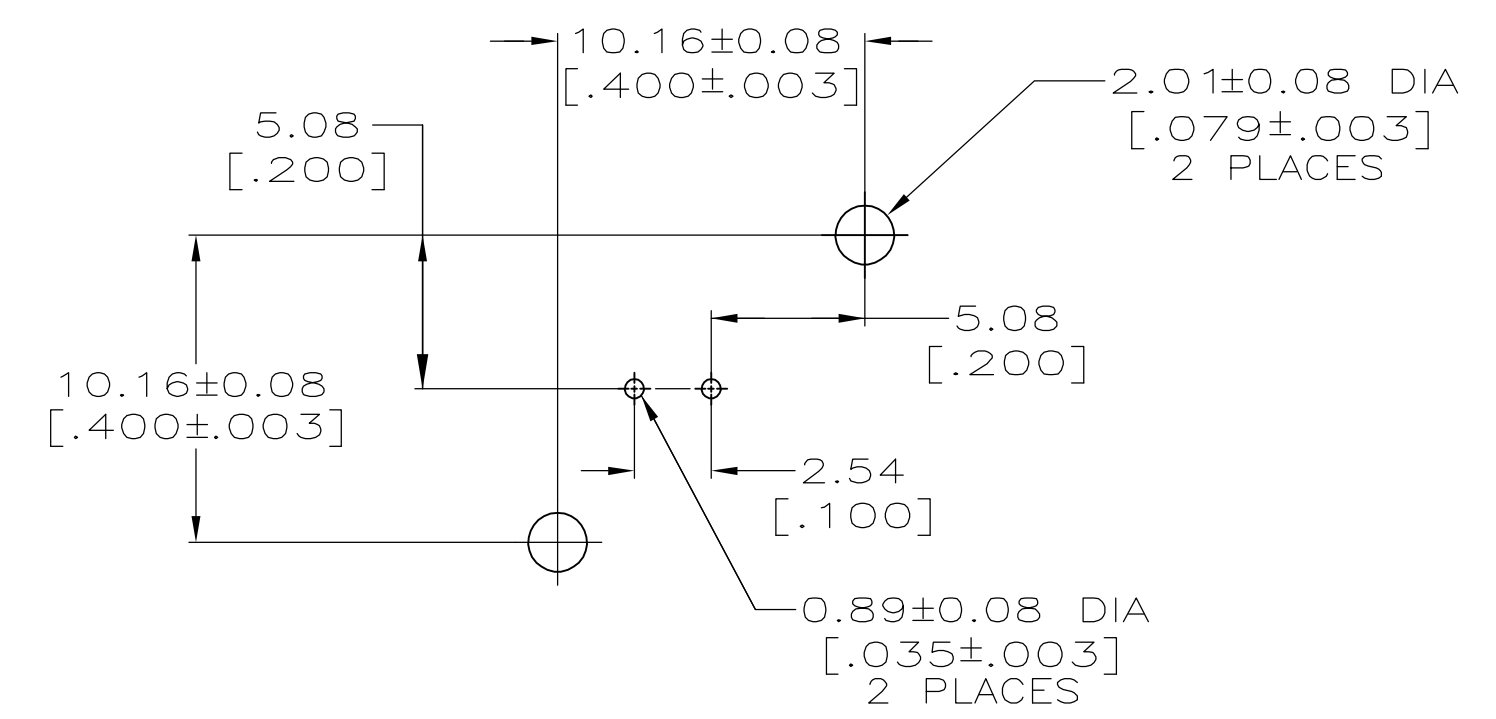

PCB CONFIGURATION

227671-1
 PART NUMBER

THIS DRAWING IS A CONTROLLED DOCUMENT.		DWG J. LIPPERT 6-30-92	Tyco Electronics Corporation Harrisburg, PA 17105-3608													
DIMENSIONS: INCHES		CHK A. GABANY 7-2-92	APV A. GABANY 7-2-92													
TOLERANCES UNLESS OTHERWISE SPECIFIED:		NAME JACK, VERTICAL, PCB, 50 OHM, SERIES BNC														
<table border="1"> <tr><td>0 PLC</td><td>± -</td></tr> <tr><td>1 PLC</td><td>± -</td></tr> <tr><td>2 PLC</td><td>± 0.05 [.002]</td></tr> <tr><td>3 PLC</td><td>± -</td></tr> <tr><td>4 PLC</td><td>± -</td></tr> <tr><td>ANGLES</td><td>± -</td></tr> </table>		0 PLC	± -	1 PLC	± -	2 PLC	± 0.05 [.002]	3 PLC	± -	4 PLC	± -	ANGLES	± -	PRODUCT SPEC 108-12078		
0 PLC	± -															
1 PLC	± -															
2 PLC	± 0.05 [.002]															
3 PLC	± -															
4 PLC	± -															
ANGLES	± -															
MATERIAL SEE NOTES 1-5		FINISH SEE NOTES 6-8		RESTRICTED TO -												
WEIGHT -		SCALE A1 00779 C=227671		REV -												
CUSTOMER DRAWING		SCALE 4:1 SHEET 1 OF 1														